

Department of the Navy SBIR/STTR Transition Program

DISTRIBUTION STATEMENT A. Approved for public release. Distribution is unlimited.

NAVSEA #2020-0473

Topic # N181-034

Surface Ship Fat Line Towed Array Cut-Resistant Vibration Isolation Module (VIM)

Hose

METSS Corporation

WHO

SYSCOM: NAVSEA

Sponsoring Program: PEO IWS 5.0

Transition Target: Vibration Isolation Module hose for towed receive arrays (e.g., TB-37)

TPOC:
(401) 832-8229

Other transition opportunities: US Navy surface ships and submarines that depend on Towed SONAR Arrays will benefit.

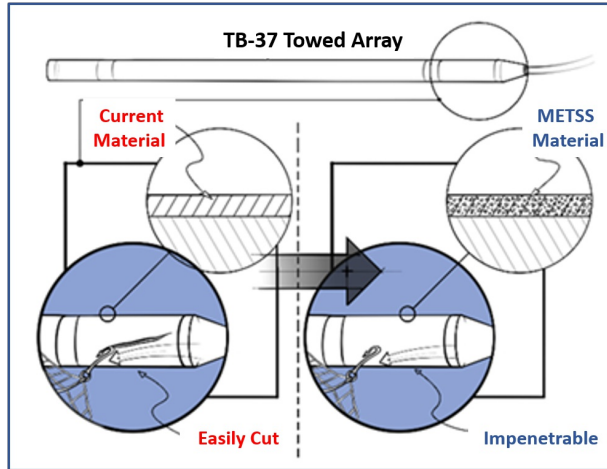

Photo Courtesy METSS Corp.

Notes: Beyond METSS' innovative materials' solution, METSS has developed a unique testing capability that uses actual fishhooks, for example, to evaluate cuts and punctures to outer cable jackets. In this way, objective analyses can be made.

WHAT

Operational Need and Improvement:

The Navy seeks innovative approaches to providing vibration isolation to TB-37 surface ship towed arrays, while reducing or eliminating susceptibility to cutting or puncturing hazards often experienced during towing, deployment, and retrieval operations.

Specifications Required:

Meet all current VIM requirements:

- 6 optical single mode fiber data paths at ~100 Mbps
- Power requirements - 500 Vdc, 2.5 A
- Reduce attenuating low frequency mechanical vibrations by ~20 dB
- Array diameter 3.5 inches
- Working tensions up to 5000 lbf
- Support 40% elongation
- Bulk specific gravity between 1.025 and 1.040 (under waterline)
- Sustain 5-year lifespan; preventing seawater ingestion and/or internal Isopar fluid expulsion

Technology Developed:

METSS is incorporating novel additives to the existing outer jacket material to improve the abrasion- and cut-resistance of the VIM hose. METSS is also addressing manufacturing variables and processing tolerances, which will inherently improve efficiency and reduce costs. METSS has focused exclusively on the outer jacket design to meet the requirements without prolonging technology integration

Warfighter Value:

- Substantial improvement to array Operational Availability (AO)
- Reduce maintenance costs
- Improve VIM's cut resistance without sacrificing mechanical "softness" required to isolate the receive array elements from speed-related turbulence

WHEN

Contract Number: N68335-19-C-0504 **Ending on:** August 6, 2021

Milestone	Risk Level	Measure of Success	Ending TRL	Date
Complete SBIR Phase I	Low	Prove feasibility of incorporating additives to existing outer jacket formulation by performing lab-scale mechanical testing	TRL 3/4	August 2019
Awarded Phase II Base	Low	Continue development and testing methods	TRL 4	August 2019
Build Prototype VIM Hoses	Low	Successfully manufacture VIM hoses using existing production methods	TRL 5/6	October 2019
Innovate VIM Hose Manufacturing Practices	High	Demonstrate ability to produce VIM hoses	TRL 5/6	January 2021
Meet LRIP Requirements	Med	Demonstrate Improved cut resistance while maintaining required mechanical properties	TRL 6	April 2021
Complete Qualification Testing	Low	Meet all Navy requirements in relevant environment	TRL 8	August 2021

HOW

Projected Business Model:

Stand-up manufacturing operations for TB-37 VIM hoses.

Company Objectives:

Streamline VIM hose production processes and reduce reliance on human factors. Supply materials to towed array manufacturer prime contractor(s). Become the supplier of choice for VIM hoses for all other towed receive array systems.

Potential Commercial Applications:

Within the Navy, all towed receive arrays benefit from cut-resistance material technology. Across DoD and commercial industry, rubber hoses (e.g., fuel transport hoses) that experience failure due to abrasion and cutting could also benefit.

Contact: Brian Collett, Managing Director
bcollect@metss.com (614)797-2200