

## WHO

**SYSCOM:** NAVAIR

**Sponsoring Program:** JSF-MS

**Transition Target:** Aircraft and ship RF photonic systems

**TPOC:**

(301)342-9115

**Other transition opportunities:** All

DOD Branches:

Microwave photonic links for radars

Antenna remoting and sensing,

Electronic warfare

(airplanes, helicopters, ships, submarines)

Commercial Markets:

Telecommunications (5G standard)

Fiber-wireless

Infrastructure

Sensing markets

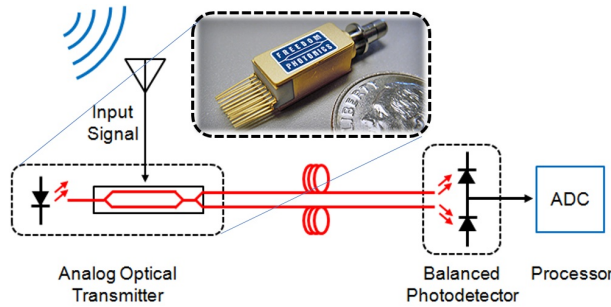

Freedom Photonics, Copyright 2017

## WHAT

**Operational Need and Improvement:** Avionic RF coaxial cable systems are bulky, heavy, have high RF loss over longer path lengths, and require heavy shielding for electro-magnetic interference (EMI). Optical fibers provide a nearly loss-less transmission medium for RF signals, are very lightweight, EMI immune with no shielding requirement. Replacing coaxial cables by RF photonic links promises drastic weight reduction and low-loss ultra-broadband RF signal transport. A ruggedized, wideband, high-power, optical laser transmitter with high linearity is a key component required for the realization of these links.

**Specifications Required:** Integrated laser and intensity modulators operating at 1.55 micron are desired with a minimum linewidth requirement of less than (<) 200 kHz and ideally < 100 kHz, and relative intensity noise of < -169 dBc/Hz from DC to at least 20 GHz. The intensity modulator should have a 3 dB bandwidth of at least 20 GHz and ideally 40 GHz, with a radio frequency (RF)  $V_p < 3 V$  at 1 GHz, a reflection coefficient (S11) of < 15 dB and 25 mW output power when biased at quadrature. The extinction ratio is required to be > 20 dB but is desired to be > 25 dB.

The integrated device should be designed such that dimensions in height and width are feasible for packaging at 1 cm by 1 cm with a length not to exceed 15 cm. Ideally, the dimensions should not exceed a packaging requirement of 5 mm by 5 mm by 10 cm for the integrated laser and modulator interface. Input - female K connector (2.92 mm) and bias control for the modulator, as well as laser bias and thermal electric cooler (TEC) control if necessary and a fiber output connector FC/APC.

**Technology Developed:** Freedom Photonics is using InP based laser and modulator technology, successfully demonstrated in Phase I, and a ruggedized, hermetic package design. This is a wafer-scale, low production cost, low size, weight and power solution.

**Warfighter Value:** Coaxial cable replacement by lightweight optical fiber RF photonic links, weight reduction, EMI immunity, broadband transmission of electronic signals for data acquisition, sensing and surveillance, very efficient links, ability to carry more payload and process more information.

## WHEN

**Contract Number:** N68335-17-C-0114 **Ending on:** October 21, 2019

Milestone	Risk Level	Measure of Success	Ending TRL	Date
Laser demonstration	Med	Key specs met on chip	4	April 2018
Transmitter demonstration	Med	Key specs met on chip	4	April 2019
Packaged module demonstration	Med	Key specs met in package	4	October 2019

## HOW

**Projected Business Model:** Freedom Photonics will search in Year 2 of this SBIR Phase II program for government and private investment to bring these products to market in Phase III.

**Company Objectives:** Freedom Photonics will design and manufacture integrated transmitters for specific and demanding requirements in terms of size, weight, performance, reliability, ruggedness, and cost. These transmitters will provide many advantages in terms of performance over existing transmitter technologies. During this technology development phase, we will maintain close relationships with the NAVAIR customer and potential prime DoD system integration companies. We will establish a transition plan to reach the highest technical and manufacturing readiness levels required to incorporate these receivers into deliverable systems.

**Potential Commercial Applications:** Commercial RF photonic systems and links (5G wireless phone, television, etc), sensing and surveillance systems; fiber-optic telecommunications and data communications networks; and high speed communications within a vehicle, such as airplanes, ships, or trains.

**Contact:** Dr. Milan Mashanovitch, CEO  
[info@freedomphotonics.com](mailto:info@freedomphotonics.com) 805-967-4900 x7003