

Department of the Navy SBIR/STTR Transition Program

DISTRIBUTION STATEMENT A. Approved for public release. Distribution is unlimited.

NAVAIR JS18-947

Topic # N152-090

GATED PH II - Multi-Wavelength and Built-in Test Capable Local Area Network Node

Packaging

Freedom Photonics LLC

WHO

SYSCOM: NAVAIR

Sponsoring Program: JSF

Transition Target: JSF

TPOC:

(301)342-9115

Other transition opportunities: Navy platforms considered for this project:

- On-board of Navy aircraft (JSF, P-8), Unmanned Air Vehicles (UAVs) (X-47B, MQ-4C, MQ-8B and MQ-8C) and ships

Potential defense markets under consideration are:

- Fiber-optic communications systems on naval, air, space and ground defense platforms
- Electronic warfare systems

Government markets, other than Defense, to be addressed:

- NASA intra-satellite fiber-optic communications
- DHS data communications networks
- Intelligence community data communications networks

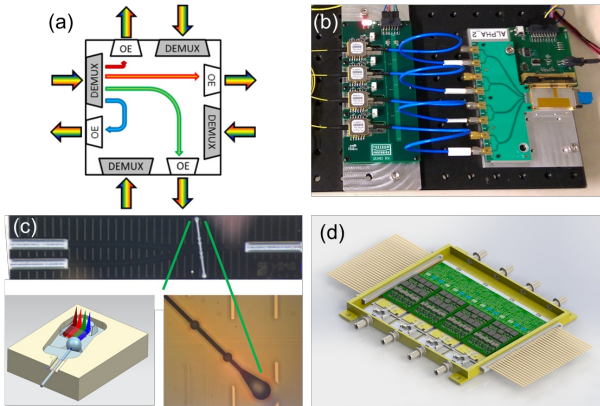

Image courtesy of Freedom Photonics, Copyright 2018

WHAT

Operational Need and Improvement: The Navy is interested in advancing built-in test (BIT) capable digital avionics single mode WDM local area network (LAN) node technology. Application of this technology on DoD aviation platforms will enable a drastic increase in the aggregate transmission bandwidth and network node connectivity, reliability and maintainability relative to today's copper and single-wavelength fiber optic point-to-point link designs.

Specifications Required: Final optical WDM node implementations shall meet the following Navy-defined SWaP requirements, as indicated in the solicitation: Size: Package height shall be less than 8 mm Threshold / 5 mm Objective; Package footprint shall be less than 100 cm² Threshold / 50 cm² Objective. Mass: Package shall be less than 1,000 grams Threshold / 500 grams Objective. Power: Package shall require less than 12 W of electrical power.

Technology Developed: The goal of the Phase II Technical Effort is to develop a miniaturized, low-profile (5mm), small footprint (75x65 mm²) node module, meeting the performance requirements specified by the Navy customer, using our already highly compact quad tunable transmitter technology, and a miniaturized version of the 4-channel WDM receiver.

Warfighter Value: Current military avionic platforms support point-to-point optical links. Physical changes to the cabling are required to add new equipment, leading to down-time of the platforms, and major upgrade costs.

Optical WDM node deployment will enable future-proofing of the military aircraft, with high-bandwidth links available for current and future weapons systems. New systems will be easily added, efficiently and with minimal cost. Additionally, the new Node technology will enable built-in-test, thus reducing maintenance complexity and down time.

WHEN

Contract Number: N68335-17-C-0198 **Ending on:** April 30, 2020

Milestone	Risk Level	Measure of Success	Ending TRL	Date
Transmitter Demonstration	Low	Key specifications met	4	October 2018
Module Demonstration	Med	Key specifications met	4	July 2019
Full Node Demonstration	Med	Key functionality met	4	April 2020

HOW

Projected Business Model: Freedom Photonics will search in Year 2 of this SBIR Phase II program for government and private investment to bring these products to market in Phase III.

Company Objectives: Freedom Photonics will design and manufacture the key sub-components (integrated transmitters and receivers), as well as the node modules for specific and demanding requirements in terms of size, weight, performance, reliability, ruggedness, and cost.

Derivative transmitter and receiver products will be pursued for commercial marketplace, including telecom and datacenter applications. These transmitters will provide many advantages in terms of performance over existing transmitter technologies.

During this technology development phase, we will maintain close relationships with the NAVAIR customer and potential prime DoD system integration companies.

We will establish a transition plan to reach the highest technical and manufacturing readiness levels required to incorporate these receivers into deliverable systems.

Potential Commercial Applications: Both the underlying technology and the derivative technologies have significant commercial potential in the telecommunications and data communications networks and high speed communications within a vehicle, such as airplane, satellite, ship or train

Contact: ,