

Department of the Navy SBIR/STTR Transition Program

DISTRIBUTION STATEMENT A. Approved for public release. Distribution is unlimited.

ONR Approval #43-4388-18

Topic # N16A-T024

SOCRATES™ Maritime Multi-access Optical Communication System
SA Photonics, Inc.

WHO

SYSCOM: ONR

Sponsoring Program: Code 32 - Maritime Sensing Program

Transition Target: SSPDD, SHD-FY16-05 "Surface Ship Periscope Detection And Discrimination"

TPOC:

Mr. Mike Wardlaw
mike.wardlaw@navy.mil

Other transition opportunities: This free space optical (FSO) communication technology is not limited to the sponsoring program. In addition to all Navy ships and related assets, SA Photonics is also pursuing uses with all DoD manned and unmanned aerial vehicles, terrestrial vehicles, and various ground communication systems.

Notes: The image at right shows SA Photonics' Secure Optical Communication & Ranging Transceiver System's (SOCRATES™) multiple compact optical heads with independent Risley Prism based beamsteering. A series of these are stacked vertically to compose the "Photonic Multicast Mast Unit" (POMMU).

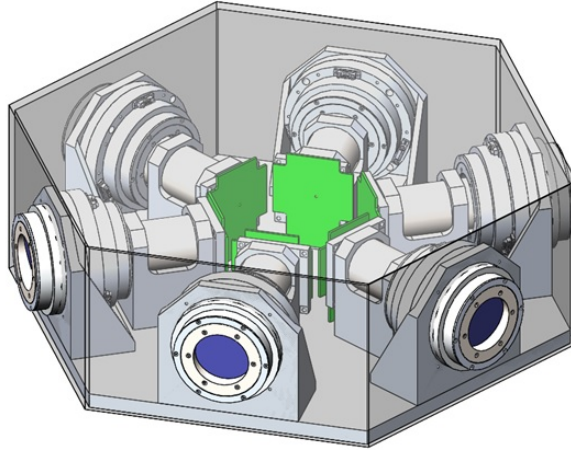

Copyright 2018, SA Photonics, Inc.

WHAT

Operational Need and Improvement: FSO communication is desired for Navy's tactical and strategic awareness, as it has numerous advantages including high data rates, immunity to interference, and low probability of interception and detection. However, traditional laser communications systems have been designed primarily for single point-to-point links and are based on mechanically-intensive and non-scalable technologies. Resultingly, a need exists for a multi-point system that extends existing methods by taking advantage of both temporal and spatial dimensions. This technology provides an optical point-to-multi-point communications system which is low SWaP, highly scalable, and affordable.

Specifications Required: The optical point-to-multi-point communications system developed is to have a weight under 50 lbs., dimensions less than 1 ft. diameter X 3 ft. high, power consumption less than 3 kW, have spectral scalability from visible through IR, and with a cost under \$250k per unit. The angular coverage provided is to be 360 degrees, with no less than 10 degrees elevation coverage.

Technology Developed: SA Photonics' solution includes our POMMU concept, wherein point-to-multi point FSO communication systems are placed on the mast of the command ship. A single POMMU has multiple compact optical heads, and allows communication with multiple remote terminal units. SOCRATES™ supports two modes of communication: high bandwidth, long-reach spot beam operation, and wide instantaneous multicast operation. Together these modes allow multipoint operation, optical spatial diversity, and high data rates.

Warfighter Value: SOCRATES™ allows significant improvement in communication speed, safety and effectiveness, both in friendly and hostile environments. Key among the warfighter benefits provided by this technology are lower susceptibility to jamming, substantial improvement in lowering the probability of detection and interception, higher data rates, and reduced SWaP.

WHEN

Contract Number: N68335-17-C-0539 **Ending on:** August 16, 2019

Milestone	Risk Level	Measure of Success	Ending TRL	Date
Preliminary Design Review	N/A	Design Analysis Complete	2	4th QTR FY18
Critical Design Review	Low	Detailed Design Complete	3	1st QTR FY19
M-BDS Integration & Test @ NCSU	Med	M-BDS integration complete	4	2nd QTR FY19
System Integration & Test @ SA Photonics	Low	Performance validated in lab setting	4	3rd QTR FY19
Testing at Santa Cruz	Med	Performance validated in outdoor test range	5/6	4th QTR FY19

HOW

Projected Business Model: SA Photonics intends to undergo initial production of SOCRATES™ onsite. The company has a history of successful small-scale production for commercialized SBIR products. We envision teaming with a prime contractor for SOCRATES™ product sales. We would look for the prime contractor to supply sales support, installation support, and maintenance support.

Company Objectives: SOCRATES™ is positioned to be a cost-saving and performance-improving communication tool not just for Navy ship communications, but military communications across the DoD. As a result, we are excited to present the product to a range of program offices at the FST, as well as a number of prime contractors, specifically those who work with communications.

Potential Commercial Applications: Applications include the military sea and terrestrial battle communication sectors, with potential for airborne applications. Commercial telecom markets also contain closely related applications. Furthermore, SOCRATES's hyperspectral imaging applications will allow for use with the DHS agencies, including U.S. Customs and Border Protection, Coast Guard and Transportation Security Administration (TSA) screening applications.

Contact: Jim Coward, CEO
j.coward@saphotonics.com

(415) 977-0553