

Department of the Navy SBIR/STTR Transition Program

DISTRIBUTION STATEMENT A. Approved for public release. Distribution is unlimited.

NAVSEA #2020-0462

Topic # N141-058

High Sea State Automated Deployment and Retrieval of Towed Bodies from a Small Surface Platform
Spatial Integrated Systems, Inc.

WHO

SYSCOM: NAVSEA

Sponsoring Program: Unmanned Maritime Systems (PMS 406)

Transition Target: Long Range Unmanned Surface Vessel – USMC (LRUSV-USMC) Program

TPOC:

(757)642-5133

Other transition opportunities:

Programs involving the autonomous Deployment and Retrieval (D&R) of Unmanned Underwater Vehicles (UUV) and Unmanned Surface Vehicles (USV) by a USV such as the Navy's Large USV (LUSV) and Medium USV (MUSV) programs.

- Other Government and commercial transition opportunities such as Textron's Common Unmanned Surface Vehicle (CUSV)

Notes: SIS would like to meet with PMS 406 and Program of Record (PoR) Managers for any USV acquisition Program.

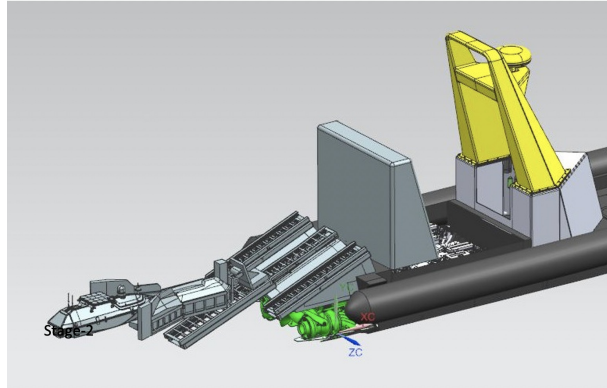

Image Courtesy of Spatial Integrated Systems, Inc. (SIS)

WHAT

Operational Need and Improvement:

- Autonomous D&R of unmanned vehicles by other unmanned vehicles is sea state limited due to wave-induced relative motion.
- Current operations require a significant amount of human interaction to minimize the probability of impacts and a collision between vessels, and the physical retrieval of an unmanned vehicle aboard another vessel.
- Future operations envision this work being done autonomously and unmanned in up to Sea State (SS) 4.

Specifications Required: Develop a D&R system suitable for employment on a surface craft of 10-12 meters in length operating in SS 4 with the ability to tow bodies of 150 lbs. Demonstrate the ability to cross-deck the D&R system between various surface platforms.

Technology Developed: Leveraging their extensive sensor and intelligent autonomy experience, SIS is developing an Autonomous Deployment & Retrieval System (ADRS) that will enable safe unmanned D&R operations in high sea state conditions and is Expeditionary in nature – increasing operational flexibility.

Warfighter Value: SIS's ADRS technology will enhance operational flexibility and warfighting capability by enabling forces to safely and autonomously deploy and retrieve small to very small USVs and UUVs in contested environments from autonomous host USV platforms for the purpose of refueling, reuse, and redeployment for additional missions. The incorporation of SIS's ADRS has the potential to revolutionize naval warfare and is a force multiplier for unmanned operations.

WHEN

Contract Number: N68335-20-C-0245 **Ending on:** September 30, 2022

Milestone	Risk Level	Measure of Success	Ending TRL	Date
Define requirements of Deployment & Retrieval System	N/A	Critical Design Review	3	August 2020
Hardware design and development	Med	Successful validation in a laboratory environment	4	May 2021
Software design and development	Med	Successful validation in a laboratory environment	4	August 2021
System integration to an USV	Med	Fully integrated system to a government furnished USV and successful testing in a relevant environment	5	September 2021
Simulation and Testing	Med	Successful simulation, and ashore and on water testing in a relevant environment	6	November 2021
Demonstration on water	Med	Successful demonstration in a operational environment	7	July 2022

HOW

Projected Business Model: SIS intends to build near-term production models of ADRS through contract manufacturing. It is envisioned that production models for the intended Government USV will be sold to the Prime Integrator.

USMC & USN require USVs with the ability to autonomously launch and recover USVs and UUVs so they can be refueled and redeployed for other missions. ADRS will enable this ability. SIS will meet the Marine Corps Systems Command (MCSC) schedule where the system is fully qualified and can be inserted into a system for acquisition such as Long Range Unmanned Surface Vessel (LRUSV) and will be ready for fielding on a US Navy USV program.

SIS will market this technology to commercial interests such as the gas and oil industry for use as a cost reduction technology in the inspection of oil platforms and bottom surveying.

Company Objectives: For SIS's innovative ADRS to become the system of choice for autonomous deployment and retrieval of USVs and UUVs from host unmanned surface platforms that takes the human out of the loop (physical interaction) and places them on the loop (monitoring operation).

Potential Commercial Applications: Commercial applications include use for:

1. Inspection of oil platforms, bridges, underwater tunnels, vessels, and underwater structures.
2. Bottom surveying
3. Search and Rescue operations
4. Fish finding operations

Contact: Rick Simon, Director at SIS
rick.simon@sisinc.org 757 288-9818