

Topic: N122-133

Research Associates of Syracuse

Enhanced De-Interleavers for Submarine Electronic Warfare Support (ES) Systems

This technology consists of innovative algorithms to perform clustering and de-interleaving in open architecture frameworks for submarine EW and ISR applications. It leverages RAS technology for unique emitter identification and specific emitter features, performing automatic clustering on pulse and "wideband segment" measurements, provided by multiple sensor types, for signals with multi-dimensional agilities, wide RF operating ranges, high time-bandwidth wideband/LPI signals, and other complexities. It then de-interleaves similar, same-type signals over frequency and time, classifies agilities, and provides an unambiguous emitter report. Challenging radar waveforms are addressed for which current techniques are inadequate. Key benefits include greatly enhanced capabilities to cluster and de-interleave pulses, and separate and identify emitters employing multi-dimensional agility, complex intentional modulations, large time-bandwidth waveforms, and emitters operating over very wide RF bandwidths.

Technology Category Alignment:

Preemptive/Proactive Effects

Contact:

Stan Hall

shall@ras.com

(315) 481-6548

<http://www.ras.com>

SYSCOM: NAVSEA

Contract: N00024-14-C-4079

 Corporate Brochure: https://navystp.com/vtm/open_file?type=brochure&id=N00024-14-C-4079

WHO

SYSCOM: NAVSEA

Sponsoring Program: Naval Undersea Warfare Command (NUWC), PMS-435

Transition Target: The primary military application to be initially addressed is the NUWC PMS-435 AN/BLQ-10B Increment 2 Electronic Warfare (EW) Modernization for the Virginia and Ohio class submarines.

TPOC:
(401)832-7849

Other transition opportunities:

Another NAVY candidate application is the NAVSEA Naval Surface Warfare Command (NSWC) Surface EW Improvement Program (SEWIP) Block II Field-Programmable Gate Array (FPGA) based digital receiver.

Notes: The solution addresses a wide variety of nine challenging radar waveform classes for which current approaches are noted to have problems. It leverages Research Associates of Syracuse's (RAS) Multi-Algorithm Unique Emitter Identification (EID) Small Business Innovative Research (SBIR) Phase II and Rapid Innovation Fund (RIF) efforts, among others, which have developed software modules for clustering, Radio Frequency (RF) Agile clustering, cluster correlation, track association, and emitter identification. It exploits previously developed Specific Emitter Features (SEF), not only for Specific Emitter ID (SEI), but also for cluster correlation, specific emitter tracking (SET), RF agile and pulse width/pulse repetition frequency (PW/PRF) agile processing.

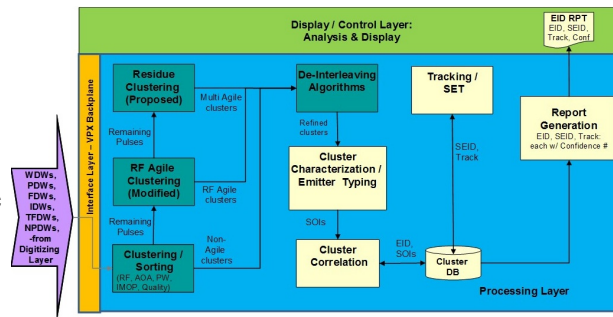

Copyright ©2015 by Research Associates of Syracuse

WHEN

Contract Number: N00024-14-C-4079 **Ending on:** August 11, 2016

Milestone	Risk Level	Measure of Success	Ending TRL	Date
Prototype Demo at RAS Facility	Med	Pulse Streams DeInterleaved	5	July 2016
Prototype Delivery	Med	Customer Acceptance	5	August 2016
Demo of DeInterleaving Algorithms Integrated with MAUEI EDM at RAS	Med	Pulse Streams DeInterleaved: EID rates maintained	6	February 2017
Algorithms Integrated with MAUEI EDM at NUWC	Med	Customer Acceptance	6	March 2017

WHAT

Operational Need and Improvement: Addresses shortfalls versus modern emitters by improving data accuracy and automation of signal processing and analyses

Specifications Required: - Very low power radars (< 200 W peak)

- Extremely low power radars (< 10 W peak)
- Real-time processing of dense environment: 5 MPPS for 10 ms burst, 2 MPPS sustained
- Pulse widths varying from 10 ns to 10 ms
- Frequency agility > 400 MHz wide
- Emitter exhibiting phase coded RF properties

Technology Developed: This SBIR develops new innovative clustering and de-interleaving algorithms, leverages and refines existing algorithms and software, and integrates them within an open architecture framework for submarine EW Intelligence, Surveillance, and Reconnaissance (EW/ISR) applications.

Warfighter Value: The key benefit provided by this SBIR to the warfighter is a greatly enhanced capability to cluster and de-interleave pulses and uniquely separate and identify emitters employing multi-dimensional agility (RF and/or PRF and/or PW), complex intentional modulations, large time-bandwidth waveforms, and emitters operating over very wide RF bandwidths.

HOW

Projected Business Model: Deliver Phase II software application program interface modules for use in Next Generation EW System Processing Layer of BLQ-10 (IV) backfit & (V) 2020 forward fit. RAS wants to license software to a system integrator and serve as a subcontractor to integrate that software into the larger system. RAS will also be looking for funds to conduct formal integration and testing into production SEWIP II systems, and then sea trials. RAS will also be looking for funds to conduct back-fit integration and testing on the RAS system and then on updated production SEWIP II systems, and then sea trials.

Company Objectives: RAS would be the prime for software application program interfaces and serve as a subcontractor for integration services for forward-fit, back-fit, and legacy system options.

Potential Commercial Applications: The algorithms for solid state radars can be applied in applications for Homeland Defense and the Coast Guard. Potential applications in the private sector include passive tracking of RF devices, wireless waveform characterization, fidelity assessment, and classification, and RF identification verification.

Contact: Stan Hall, Vice President
shall@ras.com 315-481-6548