

Topic: N171-039

## TRITON SYSTEMS, INC.

High Optical Power Hull Penetrator for Submarine Fiber Optic Systems

Triton Systems' High Optical Power Hull Penetrator is a key technology to deliver high optical power to submarine systems. Special fibers are used to mitigate issues seen in attempting to put high electromagnetic energy through fiber in a submarine. The penetrator allows more power to be delivered to a submarine system while decreasing risk to the rest of the submarine architecture by using proven hull penetrators. Triton System Inc. has a wide ranging expertise in underwater vehicle systems engineering and ultimately would like for the technology to be purchased by prime contractors for integration into submarines. As a technology incubator, Triton has helped deliver over \$4 billion in shareholder value.

### Technology Category Alignment:

**Contact:**

Christopher Leman, Jr.

[cleman@tritonsys.com](mailto:cleman@tritonsys.com)

(978) 250-4200

<http://tritonsys.com/>

**SYSCOM:** NAVSEA

**Contract:** N68335-19-C-0208

**Booth:** 3079

**Room:** FST at SeaAirSpace

**Presenting:** Apr 6th at 11:00 AM

# Department of the Navy SBIR/STTR Transition Program

DISTRIBUTION STATEMENT A. Approved for public release. Distribution is unlimited.

NAVSEA #19-640

Topic # N171-039

High Optical Power Hull Penetrator for Submarine Fiber Optic Systems  
TRITON SYSTEMS, INC.

## WHO

**SYSCOM:** NAVSEA

**Sponsoring Program:** SUB 073,  
Undersea Technology

**Transition Target:** U.S. Submarines

**TPOC:**  
(401)832-6887

**Other transition opportunities:**

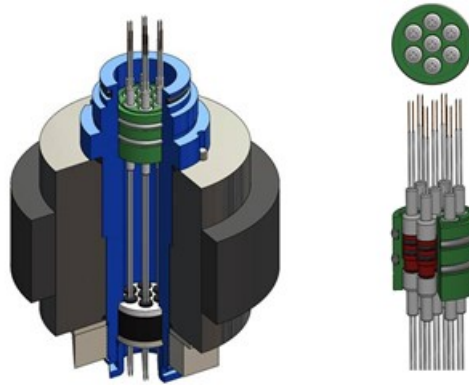

Optical Hull Penetrator with Seven Quad Feedthroughs  
Copyright 2019, Triton Systems

## WHAT

### Operational Need and Improvement:

The Navy seeks an innovative solution to integrating high optical power system subcomponents through the submarine pressure hull.

### Specifications Required:

Deliver 30 to 100 kW of optical power through the hull.

### Technology Developed:

Hull Penetrator for a high optical power fiber optic system.

### Warfighter Value:

A high optical power system would greatly enhance a high optical power fiber optic system on a submarine.

## WHEN

**Contract Number:** N68335-19-C-0208 **Ending on:** January 31, 2020

Milestone	Risk Level	Measure of Success	Ending TRL	Date
Requirements Definition	N/A	Requirements developed	2	May 2019
Fiber Design & Modeling	Med	Models indicate requirements will be met	3	October 2019
Design & Fabricate Component Prototype	Low	Delivery of feedthroughs	4	September 2020
Fabricate Assembly Prototype	Med	Delivery of penetrator	5	October 2021
Navy Testing	Med	Threshold of 30 kW optical power reached	6	November 2021

## HOW

### Projected Business Model:

The Penetrator for High Optical Power would be licensed to component manufacturers.

### Company Objectives:

To deliver the component in making High Optical Power for submarines a reality and to enable the technology to take root in the private commercial sector.

### Potential Commercial Applications:

Telecommunications, offshore oil & gas exploration, shipping, oceanography, subsea mining, and in other areas where high power optical transmission may be desired.

**Contact:** Christopher Leman, Jr., Research Development Project Lead  
[cleman@tritonsys.com](mailto:cleman@tritonsys.com) 9782504200